

London

Dual Flow | 6 and 5 Star WELS Rated

Lead FREE

All dimensions in mm

LON903500FCR
Chrome Basin Mixer

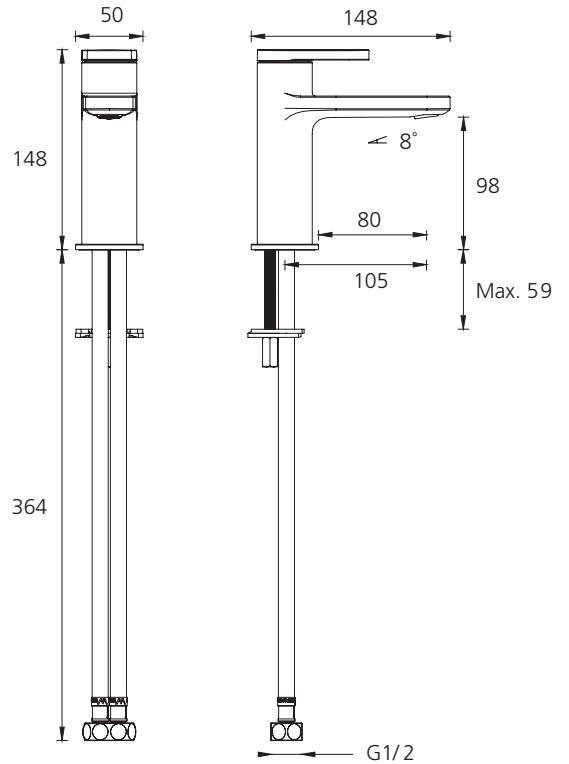

Dual WELS Rated
Product supplied with WELS 6 Star aerator installed. WELS 5 Star aerator included for optional use.

Specifications /

WELS rating	6 Star, 4.5 L per min, 5 Star, 6.0 L per min
WELS registration number	T43936, T43935
Temperature rating (min / max)	1°C - 65°C
Pressure rating (min / max)	150 kPa - 500 kPa
Finish	Chrome (electroplating)
Materials	Lead free brass body and zinc handle
Cartridge size	25 mm
Cartridge type	Ceramic disc cartridge
Product weight	1.33 kg
Mixer height	148 mm
Water supply	Mains
Warranty	15 years cartridge, body and finish; 5 years seals, tails, fittings, aerators; 1 year labour (see Oliveri website for full details)
Maintenance and care instructions	All surfaces should be cleaned with mild liquid detergent or soap and water. Do not use cream cleaners or citrus based cleaning products, as they are abrasive. Use of unsuitable cleaning agents may damage the surface. Any damage caused in this way will not be covered by warranty.