

# Venice

**Dual Flow** | 6 and 5 Star WELS Rated

**Lead FREE**

All dimensions in mm

## VE107505FGM

Gunmetal Straight Tower Basin Mixer

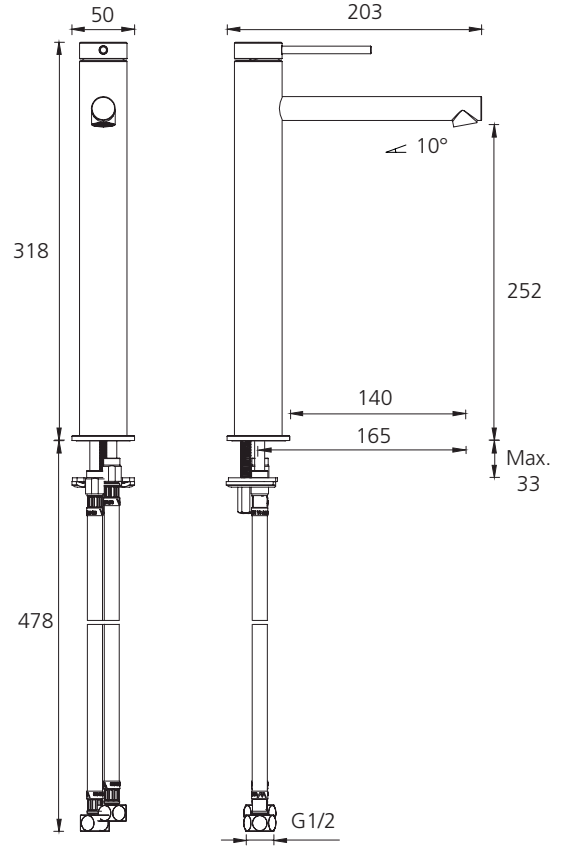

**Dual WELS Rated**  
Product supplied with WELS 6 Star aerator installed. WELS 5 Star aerator included for optional use.

### Specifications /

|  |  |
|--|--|
| <b>WELS rating</b>                       | 6 Star, 4.5 L per min, 5 Star, 6.0 L per min   |
| <b>WELS registration number</b>          | T43988, T43987   |
| <b>Temperature rating (min / max)</b>    | 1°C - 65°C   |
| <b>Pressure rating (min / max)</b>       | 150 kPa - 500 kPa  |
| <b>Finish</b>                            | Gunmetal (paint with finger print resistant coating)   |
| <b>Materials</b>                         | Lead free brass body and zinc handle with SUS handle lever   |
| <b>Cartridge size</b>                    | 25 mm  |
| <b>Cartridge type</b>                    | Ceramic disc cartridge   |
| <b>Product weight</b>                    | 1.5 kg   |
| <b>Mixer height</b>                      | 318 mm   |
| <b>Water supply</b>                      | Mains  |
| <b>Warranty</b>                          | 15 years cartridge and body; 5 years finish, seals, tails, fittings, aerators; 1 year labour (see Oliveri website for full details)  |
| <b>Maintenance and care instructions</b> | All surfaces should be cleaned with mild liquid detergent or soap and water. Do not use cream cleaners or citrus based cleaning products, as they are abrasive. Use of unsuitable cleaning agents may damage the surface. Any damage caused in this way will not be covered by warranty. |

© Registered trademark of Oliveri Solutions. Under its policy of ongoing product development Oliveri Solutions may from time to time change product specification without notice. All dimensions given are approximate and should be checked prior to installation. See Oliveri website for installation and warranty details.

Revision date: 28-01-2025

