

Barcelona

BA119506MB

Matte Black Tower Basin Mixer

All dimensions in mm

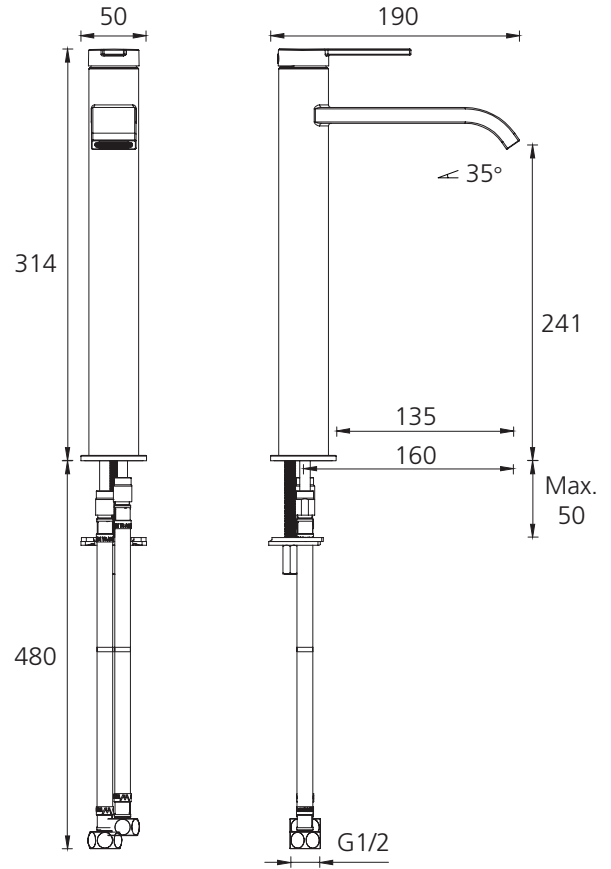

Specifications /

WELS Rating	6 Stars, 4.5 L per minute
Temperature rating (min and max)	1°C - 65°C
Pressure rating (min and max)	150 kPa - 500 kPa
Finish	Matte black (powder coated)
Materials	Brass body and zinc handle
Cartridge size	25 mm
Cartridge type	Ceramic disc cartridge
Product weight	1.73 kg
Mixer height	314 mm
Water supply	Mains
Warranty	15 years cartridge and body; 5 years finish, seals, tails, fittings, aerators; 1 year labour (see Oliveri website for full details)
Maintenance and care instructions	All surfaces should be cleaned with mild liquid detergent or soap and water. Do not use cream cleaners or citrus based cleaning products, as they are abrasive. Use of unsuitable cleaning agents may damage the surface. Any damage caused in this way will not be covered by warranty.