

# Naples

**NA7115B**

Black Line Counter Top Basin

All dimensions in mm

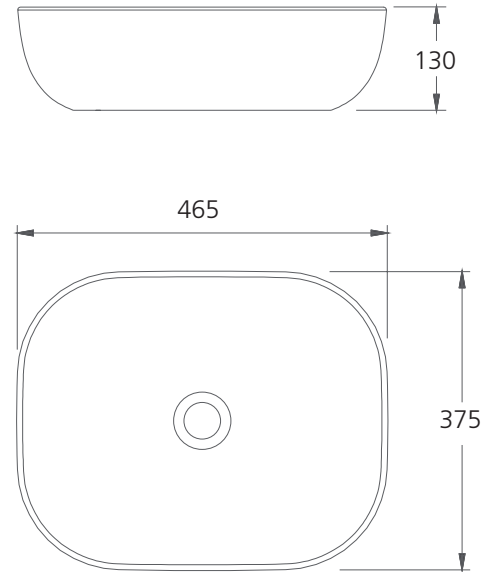

## Specifications /

<b>Tap holes</b>	Not available
<b>Waste outlet</b>	Pop up waste sold separately
<b>Overflow</b>	Not available
<b>Colour</b>	White
<b>Basin/bowl size</b>	465 W x 375 H x 130 D mm
<b>Bowl capacity</b>	10.5 L
<b>Material</b>	Vitreous china
<b>Installation</b>	Counter top
<b>Weight</b>	8.5 kg
<b>Warranty</b>	20 years replacement parts, 1 year labour (see Oliveri website for full details)
<b>Maintenance and care instructions</b>	All surfaces should be cleaned with mild liquid detergent or soap and water. Do not use cream cleaners or citrus based cleaning products, as they are abrasive. Use of unsuitable cleaning agents may damage the surface. Any damage caused in this way will not be covered by warranty.